



Bulk Material and Mining

Off-Highway Drive and Motion Systems



Market-leading Dana Brevini™
motion systems and Dana GWB™
driveshafts optimize machine
performance while maximizing yields.



People Finding A Better Way™

1904

history dating back 120 years

88

major manufacturing facilities

42K

employees globally

13K

customers in 140 countries

31

countries with Dana presence

10

country network of technology centers

Vision

Powering Innovation To Move Our World

Mission

Driving stakeholder value by powering vehicles and machines around the world shaping sustainable progress through invention and execution; and making the amazing happen wherever people live, work, and play.

Values

- Value Others
- Inspire Innovation
- Grow Responsibly
- Win Together

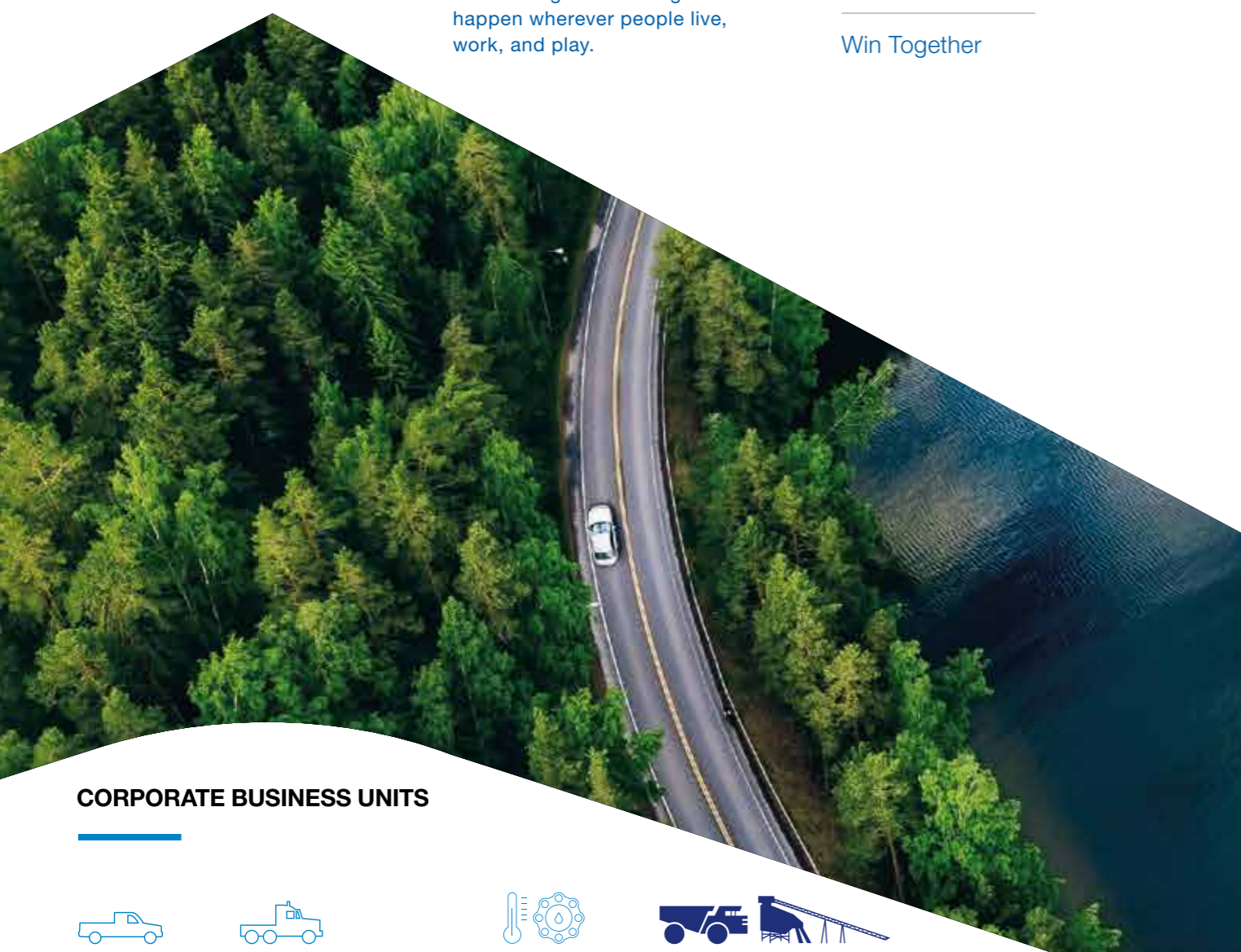

CORPORATE BUSINESS UNITS



38%

Light Vehicle Drive Systems



20%

Commercial Vehicle Drive and Motion Systems

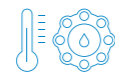

12%

Power Technologies



30%

Off-Highway Drive and Motion Systems

Off-Highway Segments

Dana leverages our global expertise to engineer the most advanced, customized product solutions for developed and emerging markets. Our drive and motion products serve a wide range of demanding industries, including applications for equipment with wheel and track drives as well as stationary machines.

Mobile



AGRICULTURE



MINING



MATERIAL HANDLING



CONSTRUCTION AND FORESTRY



COMMERCIAL TURF CARE

Industrial



BULK MATERIAL AND MINING



ONSHORE AND OFFSHORE MARINE



INDUSTRIAL AND STATIONARY EQUIPMENT



HEAVY INDUSTRY: STEEL, SUGAR, AND CEMENT



WASTE MANAGEMENT AND RENEWABLE ENERGY



PLASTIC AND RUBBER

Drive and Motion Innovations Propelling Transformations in Mining

The mining industry is facing an unprecedented transformation including accelerating demand for minerals, decarbonization initiatives, the predictive insights available through digitization, and the movement toward autonomous vehicle operation.

From field-proven systems for traditional equipment designs to next-generation hybrid and electric technologies, Dana offers a wide portfolio of drive and motion solutions to help boost the performance and profitability of mining operations.

Every mine is unique, which is why our global team designs, engineers, and manufactures systems for mobile and industrial applications customized for regional, regulatory, vehicle, application, duty cycle, supply chain, and operator requirements.

Whatever your strategy, our goals remain the same: helping mining enterprises improve efficiency, reduce fuel consumption, promote safety, simplify maintenance, extend life cycles, support sustainability initiatives, and optimize the total return on investment.

Industrial Solutions Offering Unmatched Performance

Industrial applications play a key role in maximizing throughput of high-performing mining operations. We understand downtime can result in reduced productivity and delayed shipments.

Dana produces powerful motion solutions designed and manufactured to meet the highest standards for long-term reliability and durability in conveyors, apron feeders, crushers, mining shovels, stacker reclaimers, and several other industrial applications.

Our Brevini™ gearboxes can be configured to meet precise requirements for torque density, gear ratios, and package size in industrial equipment used throughout mineral processing.

Furthermore, our heavy-duty GWB™ Industrial driveshafts are engineered for high torque transmission capabilities and superior bearing life with minimal maintenance requirements.



Boosting the performance and profitability of mining operations

Stacker Reclaimers

These versatile machines operate as both stacker and reclaimer, stacking material in stockpiles and reclaiming loads with a bucket wheel at the tip of the boom. Often less costly than maintaining a dozer fleet, stacker reclaimers can move in three directions: horizontally along the rail, vertically by lifting its boom, and rotationally by slewing its boom.



Brevini™ Winches
and Winch Drives

- Standard and special configurations lifting up to 35 tons
- Suitable for hydraulic or electric motor
- Different drum options and custom design



GWB®
Cardan Shaft

- Complete product range featuring flange / swing diameter from 120 to 1,300 mm
- Superior bearing life
- High torque capacity



Brevini™ Plano Helical Gearboxes
Compact Drives

- Light, compact solution, easy to assemble
- Spheroidal graphite cast iron housing
- Supports torque range up to 40 kNm [29,500 ft lbs]
- Premium sealing



Brevini™ Industrial Planetary Gearboxes
S Series

- Modular concept
- Extensive ratio range
- Supports torque range up to 2,200 kNm [1,600,000 ft lbs]
- Increased thermal capacity due to large bevel set



Brevini™ Plano Helical Gearboxes
Compact Drives

- Light, compact solution, easy to assemble
- Spheroidal graphite cast iron housing
- Supports torque range up to 40 kNm [29,500 ft lbs]
- Premium sealing



Brevini™ Planetary Gearboxes
Slewing Drives

- Modular design, coaxial or right angle
- Customized short or long output support
- Supports torque range up to 370 kNm [272,900 ft lbs]
- Output pinions variation to meet a range of customer needs

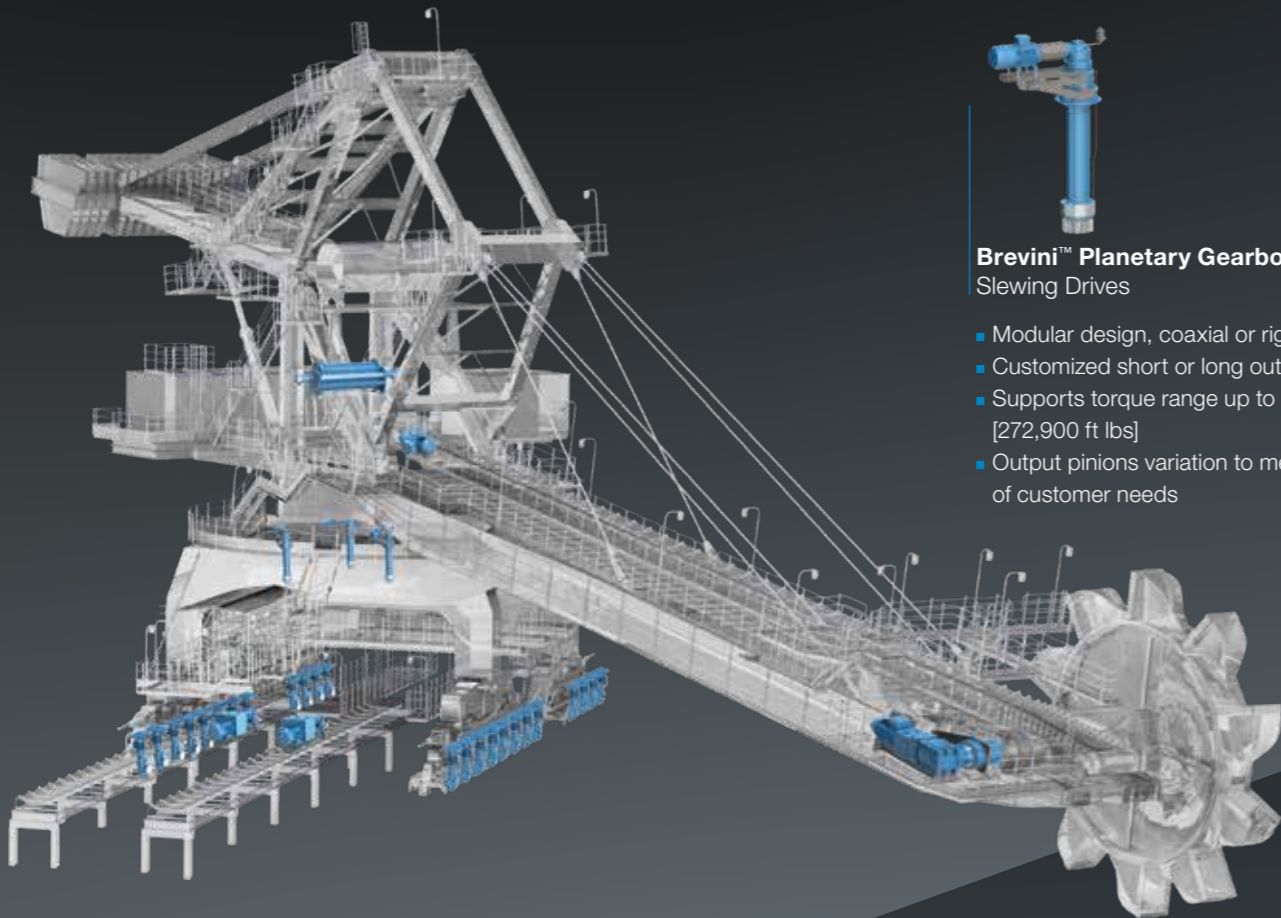

Dana offers customized solutions to meet a range of customer needs, including modular designs and add-on accessories.

Conveyors and Apron Feeders

Conveyors and apron feeders are widely used in the process of handling bulk material. Conveyors are the workhorse of mineral handling, often used in dry processing plants where they play a key role in stabilizing process flow. Typically used for small lump sizes with long-distance paths, conveyors are generally selected based on four factors: tonnage, size and type of material to be processed, incline, and distance. Apron feeders are necessary whenever the application requires a uniform flow of dry or moist fractions of rock or minerals.



Brevini™ Plano Helical Gearboxes
Compact Drives

- Light, compact solution, easy to assemble
- Spheroidal graphite cast iron housing
- Supports torque range up to 40 kNm [29,500 ft lbs]
- Premium sealing



Brevini™ Helical Bevel Helical Series:
Brevini EvoMax™ and Posired 2

- Extensive ratio range
- Evomax supports torque range up to 310 kNm [228,700 ft lbs]
- Posired 2 supports torque ranging from 340kNm up to 1,100 kNm [812,000 ft lbs]
- Increased thermal capacity
- Spheroidal graphite cast iron housing available
- Diverse low-speed shaft options

PRODUCTS FOR BOTH APPLICATIONS

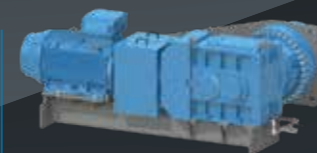

Brevini™ Plano Helical Gearboxes
High Power Series

- Extensive ratio range
- Supports torque range up to 2,200 kNm [1,600,000 ft lbs]
- Increased thermal capacity due to shared oil chamber
- Spheroidal graphite cast iron housing available



Brevini™ Helical Bevel Helical Series:
Brevini EvoMax™ and Posired 2

- Extensive ratio range
- Evomax supports torque range up to 310 kNm [228,700 ft lbs]
- Posired 2 supports torque ranging from 340kNm up to 1,100 kNm [812,000 ft lbs]
- Increased thermal capacity
- Spheroidal graphite cast iron housing available
- Diverse low-speed shaft options

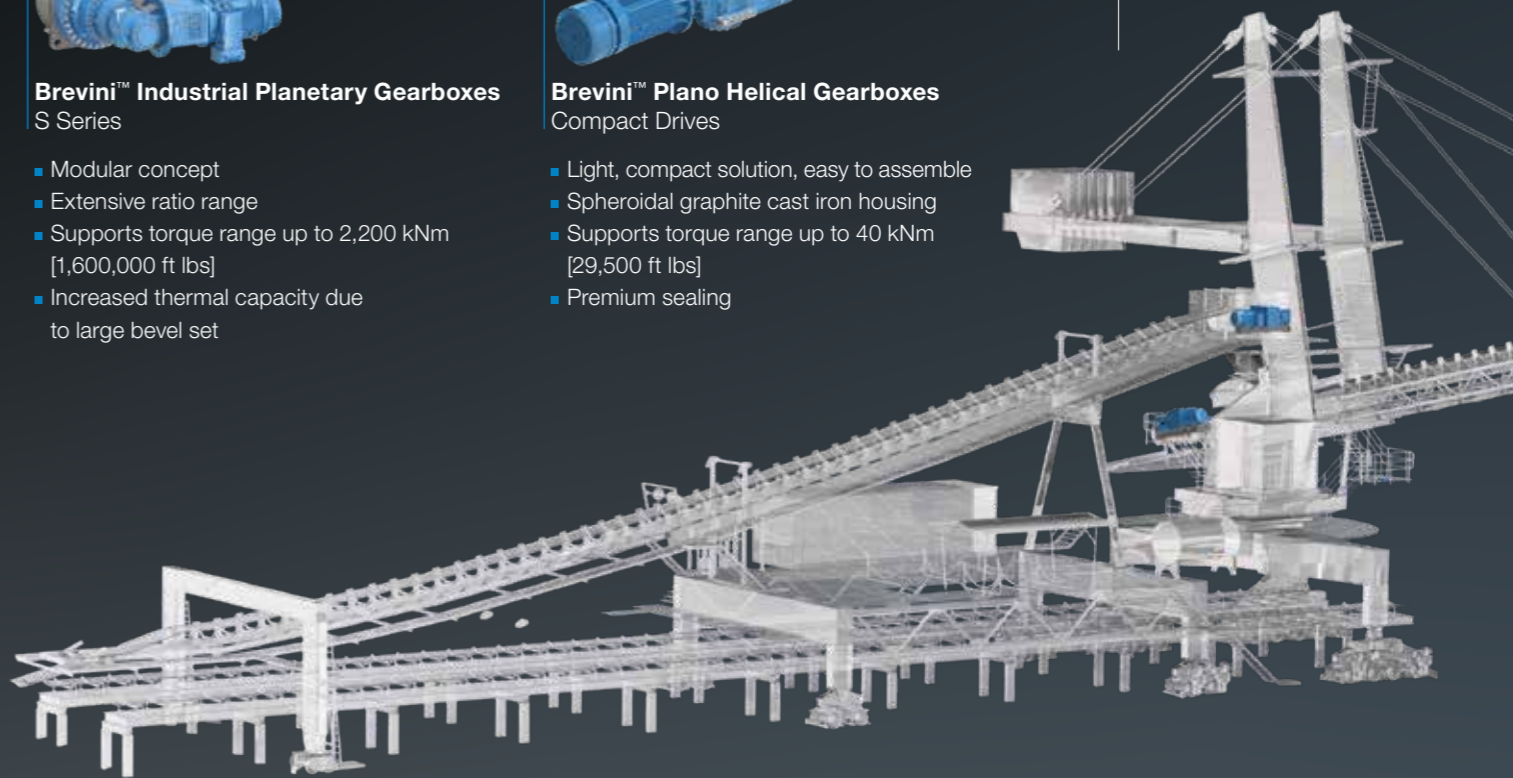

Roller Presses

In order to crush ore, roller presses, or high-pressure grinding rolls (HPGR), utilize two counter-rotating rolls — one fixed and one movable. Compared to traditional systems, this design is more stable and efficient.

Roller presses can be used for grinding as well as compacting. The drive power is transferred to the grinding rollers via multi-stage Brevini™ planetary gearboxes, which are mounted on the drive end of the roller shaft using shrink disc coupling or a low-speed flange.



Brevini™ Industrial Planetary Gearboxes – S Series

- Modular customized concept
- Supports torque range up to 2,200 kNm [1,600,000 ft lbs]
- Spheroidal graphite cast iron housing
- Special torque arm system
- Reliable operation, engineered for harsh conditions

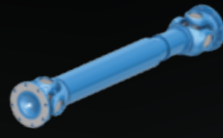

GWB® Industrial Driveshaft

- Complete product range featuring flange / swing diameter from 120 to 1,300 mm
- Superior bearing life
- High torque capacity



Brevini™ Helical Bevel Helical – Gearmotors

- Extensive torque range
- High efficiency
- Diverse low-speed shaft options

Ship-Loaders and Unloaders

These large pieces of equipment are used in shipyards to load and unload solid, bulk material such as iron ore, coal, fertilizer, grain, and others. Generally mounted on rails or sometimes tyres, ship-loaders and unloaders can move to access the length of the ship. Using separate drives, their booms can also move from front to back or up and down in order to fill the breadth of the cargo hold, and adapt to the ship's fluctuating draught while it is being loaded or unloaded. While unloading, even and complete filling of the cargo holds are facilitated by a special telescoping chute with a rotating, pivoting spoon.



Brevini™ Winches and Winch Drives

- Extensive ratio range
- Supports torque range up to 1,300 kNm [958,900 ft lbs]
- Increased thermal capacity



Brevini™ Plano Helical Gearboxes Compact Drives

- Light, compact solution
- Spheroidal graphite cast iron housing
- Supports torque range up to 40 kNm [29,500 ft lbs]



Brevini™ Planetary Gearboxes Slewing Drives

- Modular design, coaxial or right angle
- Customized short or long output support
- Supports torque range up to 370 kNm [272,900 ft lbs]
- Output pinions variation to meet a range of customer needs

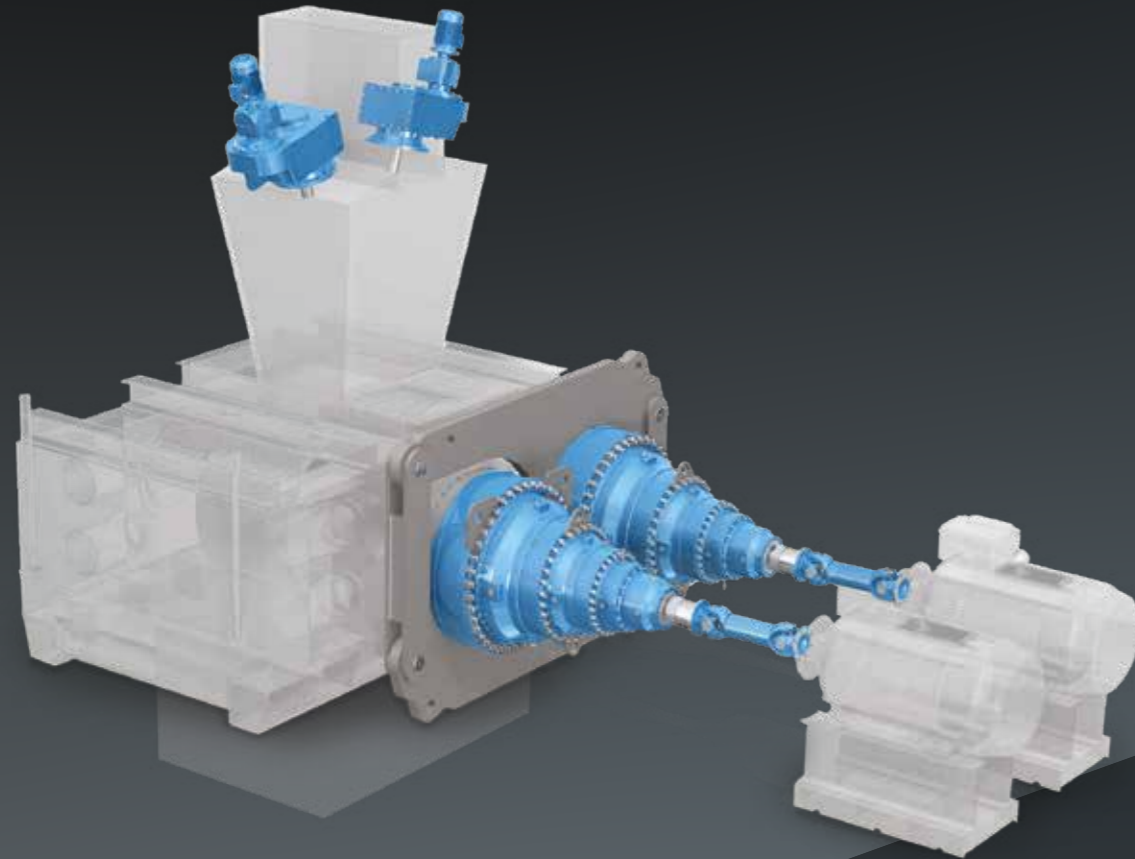

Dana offers customized solutions to meet a range of customer needs, including modular designs and add-on accessories.

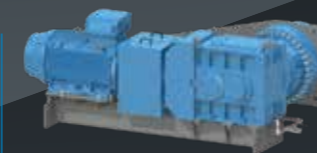
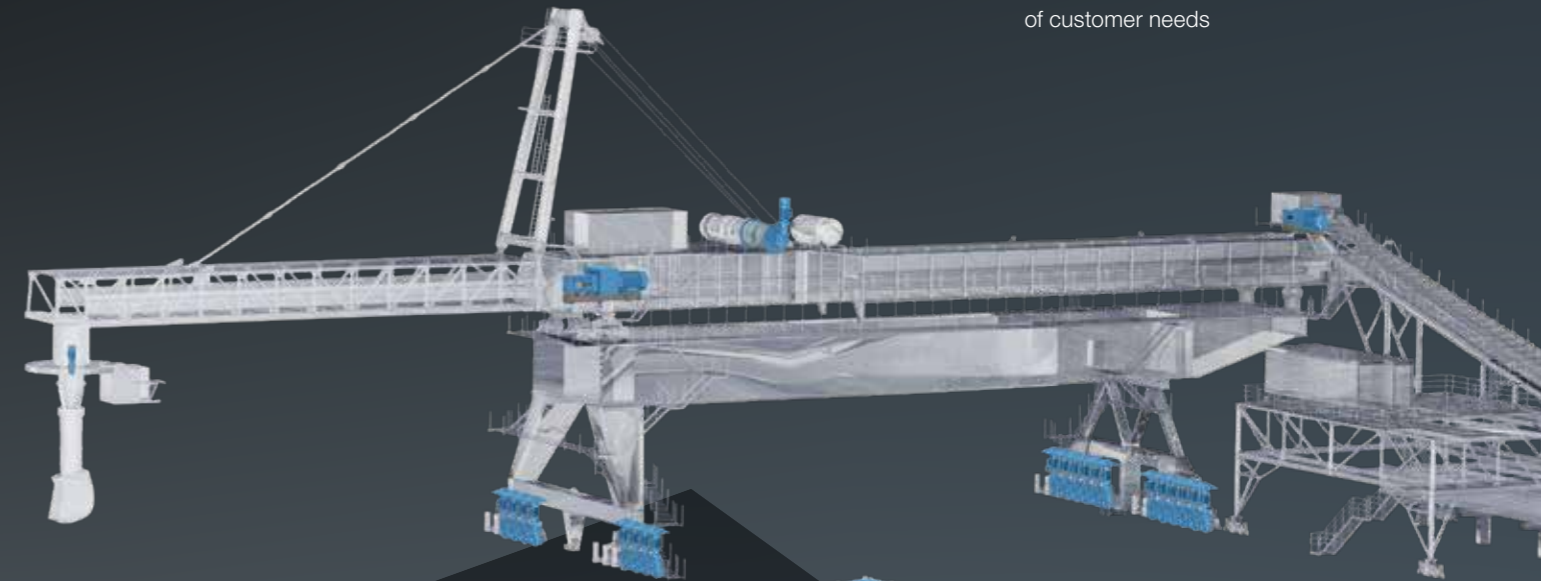

Brevini™ Plano Helical Gearboxes High Power Series

- Extensive ratio range
- Supports torque range up to 2,200 kNm [1,600,000 ft lbs]
- Increased thermal capacity due to shared oil chamber
- Spheroidal graphite cast iron housing available



Brevini™ Helical Bevel Helical Series: Brevini EvoMax™ and Posired 2

- Extensive ratio range
- Evomax supports torque range up to 310 kNm [228,700 ft lbs]
- Posired 2 supports torque ranging from 340kNm up to 1,100 kNm [812,000 ft lbs]
- Increased thermal capacity
- Spheroidal graphite cast iron housing available
- Diverse low-speed shaft options

Wagon Tiplers and Positioners

Wagon tiplers are used to unload bulk material from wagons, including materials such as coal, coke, lignite, iron ore, limestone, dolomite, among others. A complete wagon tipler system includes the positioning system, car dumper, and underground hopper along with feeders below the hopper to release bulk material. Depending on the application, this machine can be designed with a single, tandem, triple, or quadruple dumper frame. Every wagon tipler system is engineered to meet customer needs based on the type of bulk material that will be unloaded.



Brevini™ Industrial Planetary Gearboxes
High Power Series

- Extensive ratio range
- Supports torque range up to 2,200 kNm [1,600,000 ft lbs]
- Increased thermal capacity due to shared oil chamber



Brevini™ Planetary Gearboxes
Slewing Series

- Improved thermal capacity
- Robust design
- Reliable operation, engineered for harsh conditions



Brevini EvoMax™
Gearbox Series

- Complete drive system including base and bed plate
- Supports torque range up to 1,100 kNm [958,900 ft lbs]
- Spheroidal graphite cast iron housing

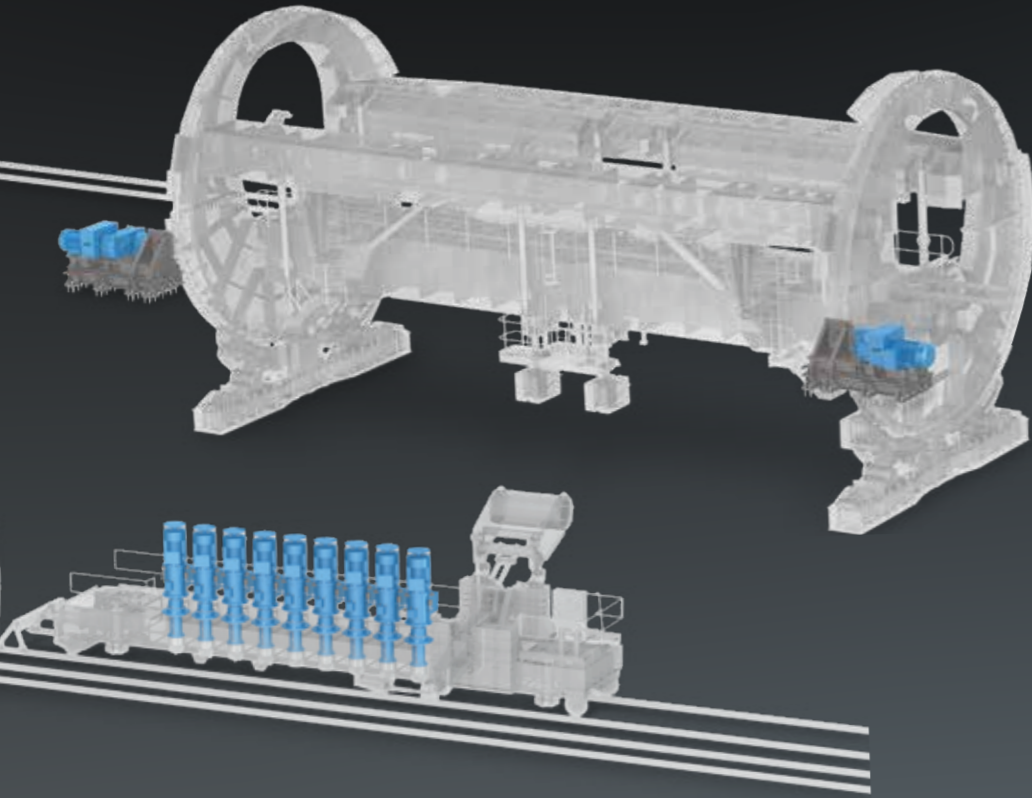

Dana offers customized solutions to meet a range of customer needs, including modular designs and add-on accessories.

Thickeners and Clarifiers

The principal task of a clarifier, also known as a juicer, is the separation of solids from the sugar cane liquid in order to minimize impurities and thereby obtain the purest juice possible. Juice is heated to help kill natural enzymes; flocculants are added as well as lime which brings the juice to a neutral pH value, a vital factor in sugar processing.

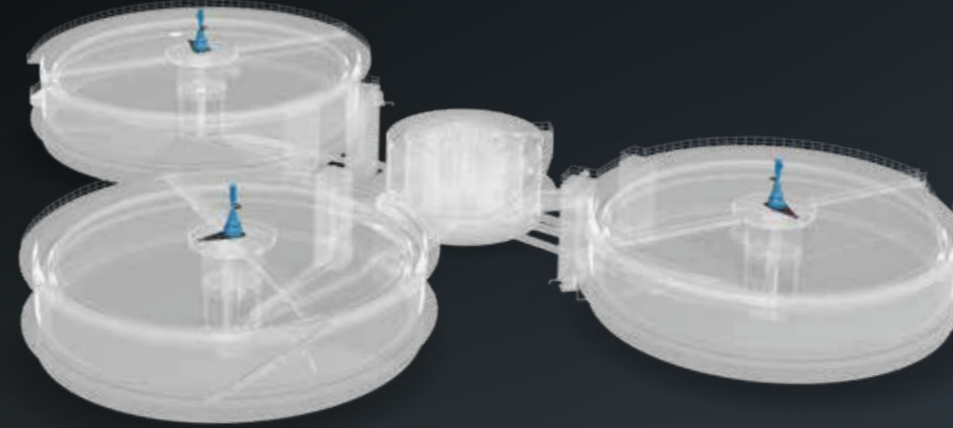

Brevini™ Industrial Planetary
Gearboxes – S Series

- Modular concept
- Extensive ratio range
- Supports torque range up to 2,200 kNm [1,600,000 ft lbs]
- Output supports design for heavy loads at low working speed
- Torque load cell system

Milling and Grinding

Once the nodular clinker issues from the sintering furnace, it needs to be ground down into a fine powdery substance. This can be done using different milling or grinding equipment: horizontal mills, hydraulic roller presses, or vertical roller mills. Horizontal mills, which are essentially large cylinders rotating horizontally or at a slight angle, mostly contain steel balls, although some mills use ceramic or rubber balls, which reduce the clinker to powder through impact and attrition.

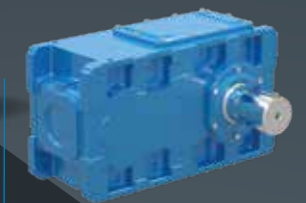
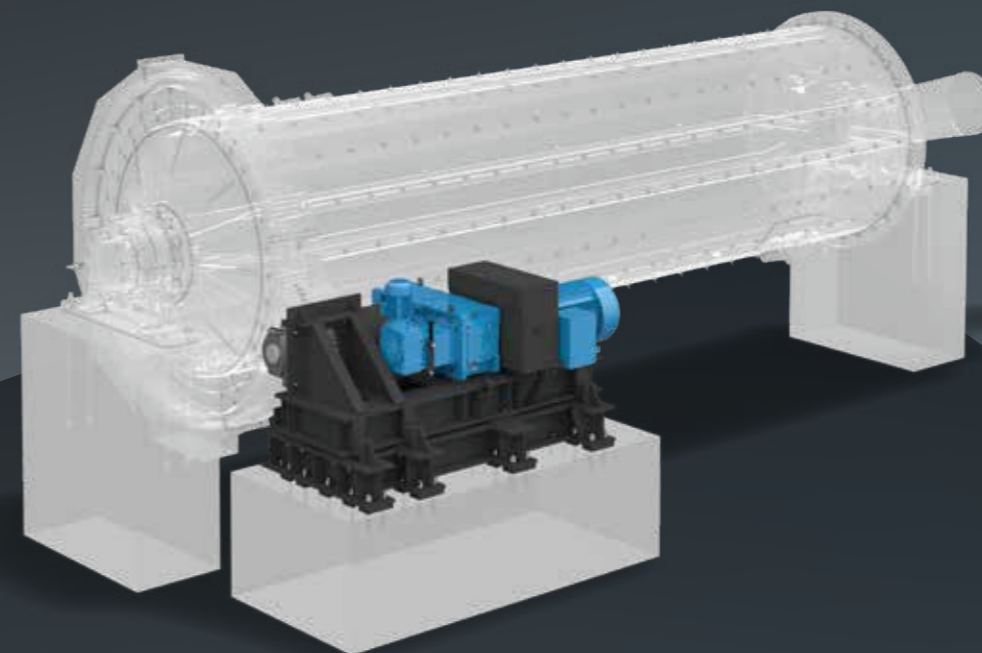

Brevini™ Helical Bevel Helical Series:
Brevini EvoMax™ and Posired 2

- Extensive ratio range
- Evomax supports torque range up to 310 kNm [228,700 ft lbs]
- Posired 2 supports torque ranging from 340kNm up to 1,100 kNm [812,000 ft lbs]
- Increased thermal capacity
- Spheroidal graphite cast iron housing available
- Diverse low-speed shaft options

Market-Driven Off-Highway Innovation

About Dana Incorporated

Over 40,000 Dana dreamers in over 30 countries drive mobility and transportation forward — wherever the road, or offroad, takes our customers and communities.

A leader in the design and manufacture of propulsion and energy-management solutions, Dana powers vehicles and machines in all mobility markets across the globe.

Delivering groundbreaking drive systems. Advancing revolutionary motion technologies. Championing leading-edge power management innovations across thermal technologies for e-Propulsion; controls and software; battery management systems; and fuel cell plates.

With a balanced portfolio — including complete in-house electrification capabilities — Dana provides class-leading products and systems supporting traditional, hybrid, and EV manufacturers. **Everywhere.**



About Dana Off-Highway Drive and Motion Systems

Dana delivers fully optimized solutions to customers in the construction, agriculture, material handling, mining, and industrial markets.

Dana.com/oh
Dana-industrial.com/contact-us

Application Policy
Capacity ratings, features, and specifications vary depending upon the model and type of service. Application approvals must be obtained from Dana; contact your representative for application approval. We reserve the right to change or modify our product specifications, configurations, or dimensions at any time without notice.

